

National Assessment and Surveys Online Program

Tailored test design 2013 research study summary

Background

In 2012 ACARA was funded by the Australian Government Department of Education to conduct research to inform decisions on the transition of the National Assessment Program – Literacy and Numeracy (NAPLAN) from paper-based to computer (online) assessments. Consequently, ACARA developed a comprehensive research program to systematically address key challenges in transitioning the paper test to an online assessment.

Research into the tailored test design

The initial phase of research, undertaken in 2012, investigated how the test delivery mode (paper vs computer) affected student performance in, and engagement with, the current NAPLAN tests. The second phase of research, conducted in 2013 and summarised here, investigated the feasibility of the enhanced adaptive test design for NAPLAN online assessments.

ACARA has proposed that future NAPLAN online tests should implement a multistage adaptive test design (the ‘tailored test design’), in which the test difficulty is adjusted to students’ needs. After students respond to a set of test items, they are provided with a subsequent set of items that best suit their observed ability (i.e. achievement level). In the tailored test design proposed for NAPLAN, students go through three stages containing item sets (testlets) of varying difficulties to complete the test as illustrated in Figure 1.

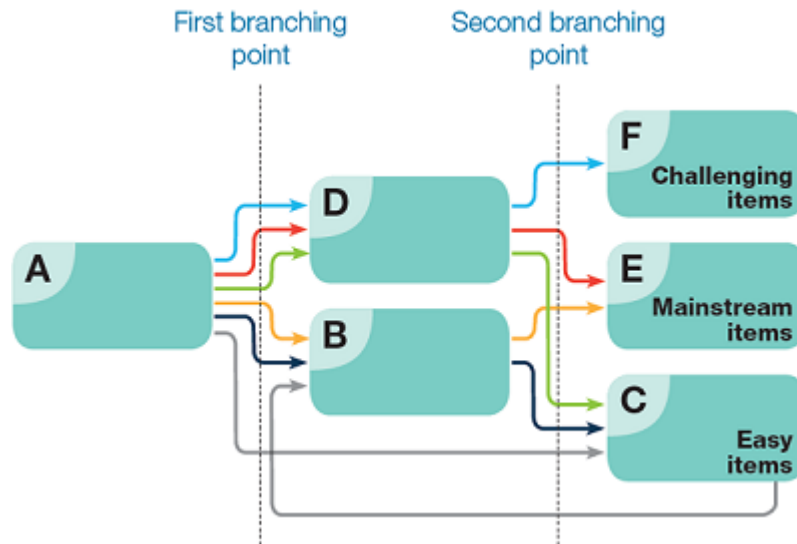

Figure 1: Tailored test design. This figure illustrates testlets and six test pathways available in TTD

Each testlet contains approximately one third of the total number of items in the overall test and is additionally representative of the whole test in terms of skills and content coverage. As a result, each student is assessed at the same level of domain breadth regardless of the test pathway taken. The test pathways are determined by the two branching points. There are six possible test pathways including a pathway for students who might be struggling to engage appropriately with items in the first testlet. These students will be forwarded to the testlet containing the least challenging items in order to ease their progression through the remaining stages of the test.

To investigate the feasibility and the benefits of the proposed tailored test design for NAPLAN online numeracy and reading tests, ACARA conducted a series of studies in 2013. The aim was to investigate measurement aspects of the test design and also the ways in which students engage and interact with the multistage adaptive test.

More than 250 schools participated voluntarily in the main empirical tailored test design study. Although being self-selected and convenient, the sample had a satisfactory diversity of students. Over 2500 students in Years 3 and 5, and 1500 students in Years 7 and 9 completed either numeracy or reading online tests. Most of testlets used in this study were created from existing NAPLAN test items that had been rendered to suit the online delivery mode.

In addition to the main study ACARA conducted additional studies:

- a) Students from 16 schools participated in structured interviews to ascertain how they reacted to key aspect of tailored test design such as the rising and falling pattern of item difficulty in a test.
- b) Investigation on whether the tailored test design can accommodate the assessment needs of students with socio-educational disadvantage in numeracy tests.
- c) In collaboration with the Northern Territory Department of Education, a study was conducted to collect information about the extent to which the proposed tailored test design provides a better testing experience for Indigenous students and students in remote communities. In this study, online tests were administered in eight Northern Territory schools, including two very remote schools.

The key findings from the 2013 research on tailored test design are as follows:

- Results of the tailored test design studies show that the delivery of multistage branching tests for NAPLAN online is sound and feasible, and that these tests offer better measurements of student performance, particularly for high- and low-achieving students. The results show that the current measurement model can be used to construct a NAPLAN online measurement scale.
- The psychometric analyses also show that further work is required to finalise the measurement aspects of the tailored test design; in particular, testlet boundaries require further refinement. (This is the focus of the 2014 research.)
- The tailored test design and the proposed branching mechanism work effectively to adapt to the different ability groups. Consequently, well-targeted tests can be administered to different ability groups, thus increasing measurement precision.
- The investigation of cognitive and behavioural engagement of students with the tailored test design showed that multistage testing will provide an opportunity for all students to be assessed by tests catering more fully for their assessment and learning needs.

In August 2014 ACARA began the third phase of its research program with the aim to further refine the measurement aspects of the tailored test design for reading and numeracy tests. This study also includes trialling of grammar, punctuation and spelling test items delivered online, including students listening to spelling items through headphones.